

CAR MONITOR

Model RCM-3000

USER GUIDE & INSTALLATION MANUAL

Car Monitor(Millennium FX) is your complete solution to provide you with live monitoring and surveillance for your vehicle. No more guessing what happens to your car while shopping, working, or staying at home.

- 1 - A small and innovative hand pager(that can be carried in the supplied belt clip, or in your pocket or handbag), will instantly alert you should your parked vehicle be violated. The alert is selectable, from either a musical melody, or a silent vibration. While no sound is emitted from the vehicle, a neat LCD display on the pager accurately monitors doors open/closed status, hood and trunk open/closed status, and hard impacts to your vehicle. It even advises whether the vehicle's engine has been started.
- 2 - The high tech display is back lit, and also indicates other useful information such as whether or not you are within the effective range of the system, the current time, a reminder alarm, alert mode selection, low battery, and more.
- 3 - **Car Monitor(Millennium FX)** uses FM and other new technologies making it suitable for any make and model of 12-volt vehicle with or without an existing car security system, and provides the highest performance, most reliable quality and longest service distance (This range depends upon local Radio Frequency laws). **Car Monitor(Millennium FX)** is ideal for vehicles fitted with factory immobilisers, effectively increasing the level of security.

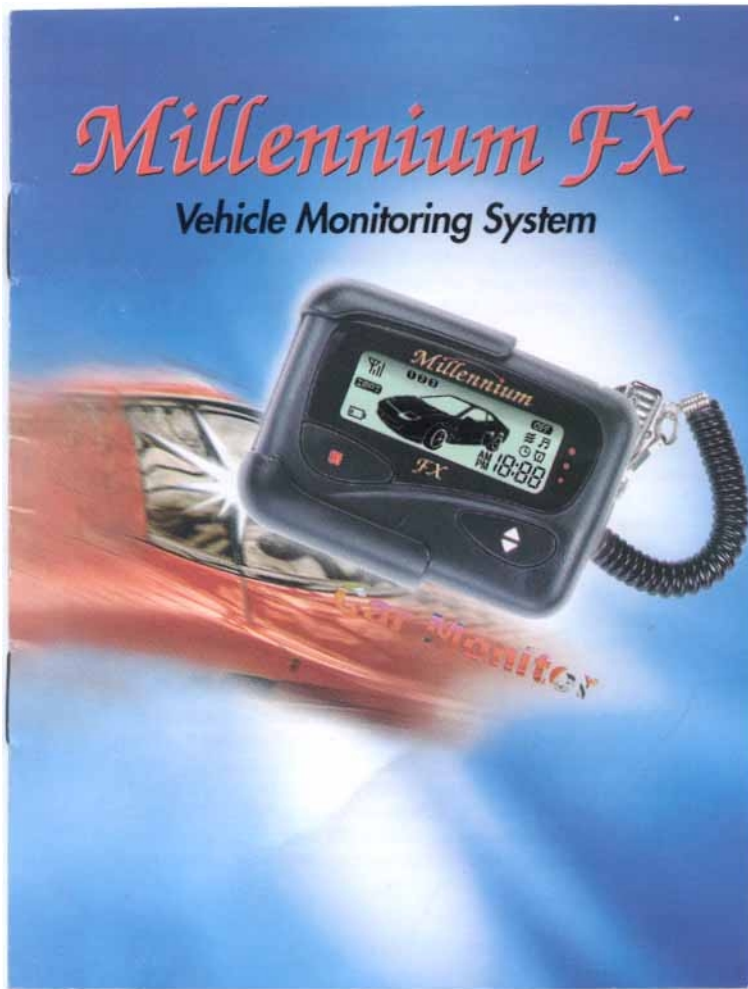

MONITORING YOUR VEHICLE

Trigger Zones

Your pager will immediately alert you of a violation to your vehicle. A Melody or Vibration will be emitted, and a visual icon will display on the LCD screen.

- 1) Door Open/Closed status
- 2) Engine ON/OFF status
- 3) Impact status (Pre-warn and Full Trigger, depending upon the existing security system)
- 4) Hood Open/Closed status
- 5) Trunk Open/Closed status

Operation

- 1) The transmitter of Car Monitor will be automatically turned off 30 seconds after the vehicle's engine is started.
- 2) When Car Monitor is installed with an existing security alarm, Car Monitor is designed to be controlled, and automatically turned ON or OFF by the operation of the existing remote control system.
As soon as the vehicle is armed, Car Monitor is turned ON.

ENHANCED USER FEATURES

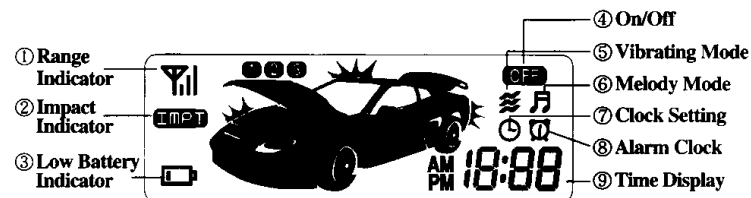

- 1) Out of Range Indicator ①. The symbol (📶) indicates that Car Monitor is within the operational range.
Out of Range Alert Selection : Silent or Tone alert.
Press Button (■) repeatedly until the symbol (📶) starts flashing.
Select ON or OFF by pressing Button (◆). Press Button (■) to confirm. When ON is set, Car Monitor will emit "beep" immediately in Out of Range Area. When OFF is selected, no sound will emit in Out of Range Area.
- 2) Low Battery Indicator ③. This symbol (🔋) flashes and emits a beep when the internal battery reaches a low level. We recommend the battery (AAA) is replaced immediately.
- 3) Resetting the Car Monitor ④. Press Button (■) once, and the symbol (OFF) will be flashing. Press button (◆) to confirm the OFF mode. Car picture will disappear. Alarm clock and time still remain functional.
- 4) Setting Vibrating Alert Mode ⑤. Press Button (■) repeatedly until the symbol (📶) starts flashing. Press Button (◆) to confirm Vibrating Alert Mode.
- 5) Setting Melody Alert Mode ⑥. Press Button (■) repeatedly until the symbol (🎵) starts flashing. Press Button (◆) to confirm Melody Alert Mode.
- 6) Setting Current Time Mode ⑦. Press Button (■) repeatedly until

the symbol(⊕) starts flashing. Press Button (◆) to select Time Setting Mode. Change the Hour, Minute and AM/PM by pressing Button (◆). To confirm each press Button (■).

- 7) Setting WakeUp Call Mode ⑧. Press Button (■) repeatedly until the symbol(⊕) starts flashing. Press Button (◆) to select WakeUp Mode. Change ON/OFF by pressing Button (◆). To confirm press Button (■). Do the same procedure to enter the time data as Current Time Mode.

SPECIFICATIONS

Transmitter		Monitor	
RF Output Power	10mW	The number of code	65,550
Modulation	FM	Sensitivity	-107dBm
Current Consumption		Current Consumption	
Standby Mode	13mA	Standby Mode	1mA
Active Mode	70mA	Active Mode	5mA
Power Source	DC 12V	Power Source	1.5V 1AAA Alkaline
Dimension	91×70×30mm	Dimension	63×44×18.9mm
Auto On/Off	Off 30seconds after Engine is Started. Starter Kill (Negative Armed)	Weight W./Battery	60g
		Auto On/Off	Same as left

CODE LEARNING

Step 1 *Installing the Control Module*

Connect all the wiring harnesses and power the module as per the installation guide. Close the door, the trunk and the hood of the vehicle.

Do not start the engine. You have 30 seconds to complete Step 2.

Step 2 *Setting Code Learning Mode for the LCD receiver*

- Press and hold Button (◆) more than 1 second or until you hear a short beep tone.
- Press Button (◆) 4 times. The current time will change to (0:00), indicating the LCD receiver is on code learning mode and is communication with the main control module.

Step 3 *Receiving ID Data*

When ID data is successfully delivered to the LCD receiver, (0:00) changes to current time and LCD screen will be back to Stand By mode by emitting a song titled Congratulation.

The Out-of-Range icon will reappear at the left top corner of the screen to confirm that the operation is terminated.

Step 4 *Testing Car Monitor*

Arm the host alarm and then Open/Close the door, the hood, the trunk or start the vehicle.

Tempered location must be displayed on the LCD screen as it occurs.

Otherwise re-do steps 1 to 4.

BLOCK DIAGRAM FOR CODE LEARNING

Install Car Monitor TX



Close doors, trunk, hood, and turn off the engine



Within 25 seconds
 Step # 1 : Press button (◆) longer than 1 second.
 Step # 2 : Press (◆) again 4 times shortly
 Time Display changed to [0:00]

Prepare RX mode to receive ID data



30 seconds

Code Learning Success



Congratulation Song emits

Check and Re-confirm

Open Door/Trunk/Hood and Start engine
 (While armed)

6

WIRING DIAGRAM INSTALLED TO OTHER SECURITY ALARM

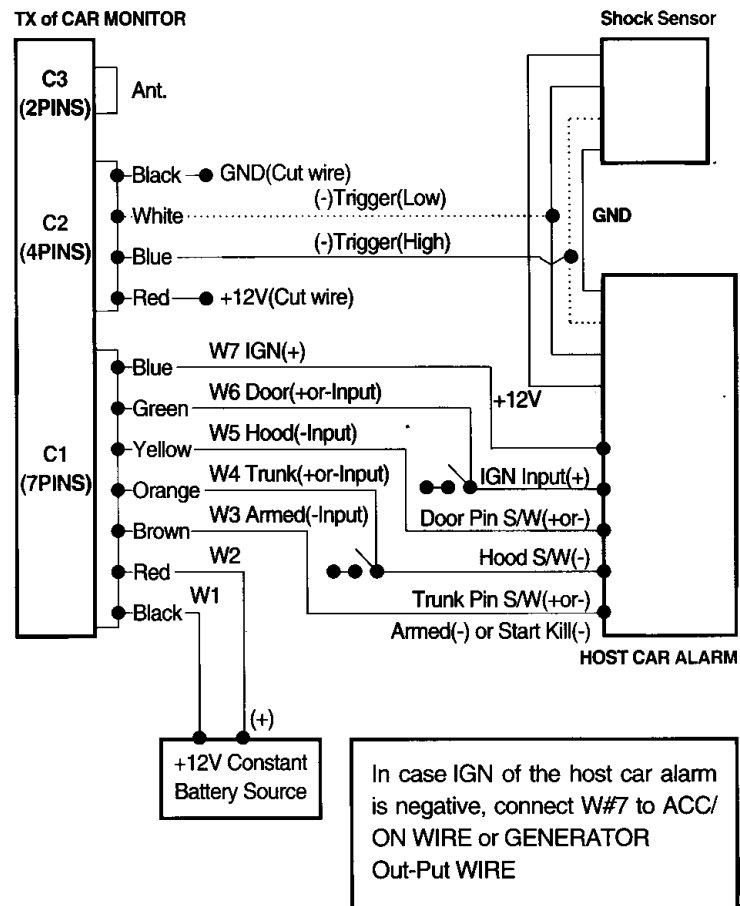

7