

Limited Warranty Statement

GNU COMMANDO LINE WARRANTY STATEMENT

GNU warrants this product to be free from defects in material and workmanship for a period of one (1) year from the date of sale to the original purchase, and not more than two (2) years from the date of manufacture. **GNU** will repair this product free of charge if, in the judgment of **GNU**, it has been proven defective within the warranty period. The product should be returned, at the customer expense, to **GNU INDUSTRIES INC., 1904 SOUTH OCEAN DR., HALLANDALE, FL 33009**. This warranty does not cover any expenses incurred in the removal and/or reinstallation of the product.

This warranty does not apply to any product damaged by improper installation, accident, misuse, abuse, improper line voltage, fire, flood, lightning, other acts of God, or a product altered or repaired by anyone other than **GNU**.

This warranty is in lieu of other warranties, expressed or implied, including any implied warranty of merchantability. No person is authorized to assume for **GNU** any other liability concerning the sale of this product.

**IMPORTANT — KEEP YOUR INVOICE
WITH THIS WARRANTY STATEMENT !**

COMMANDO

Installation Manual & Operation Instructions



REMOTE CONTROL ENGINE STARTER with Quick Stop and Anti-Freeze Modes MODELS: EZ-2200/1200

MADE IN THE U.S.A.

**IMPORTANT: THIS PRODUCT IS DESIGNED FOR USE IN
VEHICLES EQUIPPED WITH FUEL INJECTION AND AUTO-
MATIC TRANSMISSIONS ONLY!**

**Note: READ THIS INSTRUCTION MANUAL THOROUGHLY
BEFORE INSTALLATION**

TECH SUPPORT: 1-888-754-2340

EACH KIT INCLUDES THE FOLLOWING COMPONENTS:

(1) Starter control module

(1) 10-Pin wiring Harness

(2) 3-Pin wiring Harness

(1) Hood pin switch

(6) Heavy-gauge 1-pin wire harness

(1) Receiver/Antenna module (EZ-2200 only)

(1) Receiver/Antenna cable (EZ-2200 only)

(1) Status LED

(1) Program/Override switch

(2) 4-Button RF transmitters (EZ-2200 only)

Passlock/ VATS Bypass

For ease of installation we have available the Autopass module. It has all resistor values and three on-board relays for easy and convenient interfacing to GM Pass Lock and VATS systems with our remote starter systems.

It works on the 1996 and newer Chevrolet Cavaliers, Pontiac Sunfires, 1998 and newer GM trucks, Suburbans, Tahoes, Yukons, Blazers, All Passlock I ,II, III, and VATS Equipped vehicles. The part number is: SPLX-PASS-MOD (Auto Pass Module). **If you do not have the Autopass module the remote starter can be integrated with the following the diagrams below.**

Passlock Bypass Instructions for Commando Remote Starters

The 1998 GM full-sized SUVs and Trucks have a new Passlock system which is very similar to the old type VATS system with the resistor in the key. In order to bypass this system you will need to follow the following steps:

Find three small wires coming from the ignition switch. They will be red/white, orange/black and yellow.

Start the vehicle with the switch.

Cut the thin yellow wire in half.

Strip back the insulation on the Orange/Black wire, then measure the resistance between the key side of the Yellow wire and the Orange/Black wire.

Once that is done purchase a resistor within 5% of the measured value.

The final step is to install the resistor per one of the two diagrams below.

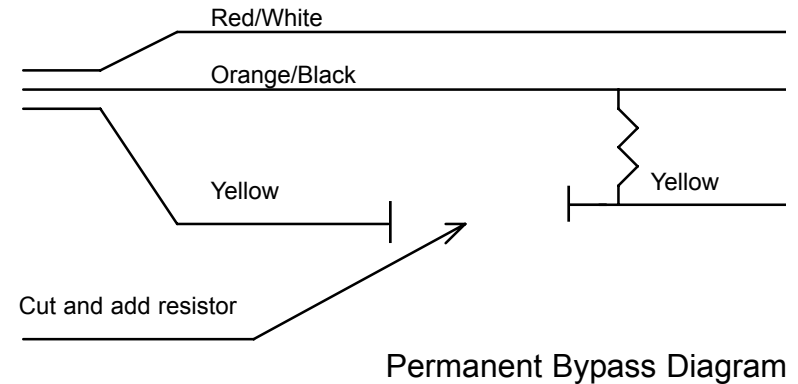

GM PASSLOCK II SECURITY SYSTEMS

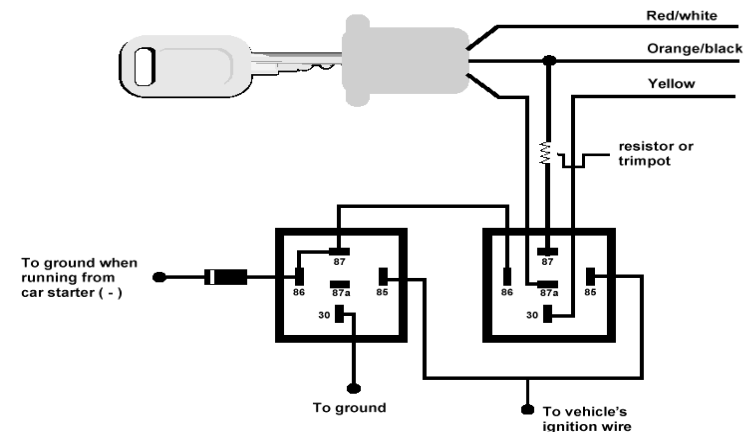

INTERFACING TO GM VATS-PASS KEY SYSTEM

NOTES:

If the ignition key does not have a resistor pellet, the vehicle does not have the VATS System.
We do not recommend disabling the VATS System as a short cut.
Do not confuse VATS wires with the labeled air bag restraint wiring.

INSTRUCTIONS:

On vehicles with the VATS System, the ignition key has a resistor pellet that operates the pass key decoder module. When the ignition key is inserted, the decoder reads the pellet. If the reading is not correct, the starter and fuel pump will be disabled for approximately 4 minutes. To allow remote starting you will have to emulate the key being inserted in the ignition.

Do not make any connections to the VATS System wiring until the remote starter is installed and working properly. To allow temporary remote starting before making any connections insert the ignition key fully into the lock cylinder. (You do not need to turn the key)

These connections operate the pass key decoder while the vehicle is in remote control status only and does not interfere with the normal operation of the VATS System.

Using an Ohm Meter, connect one test probe to each side of the ignition key pellet on the silver tabs.

Record the reading.

Purchase a ¼ or ½ watt resistor within 5% of the recorded value.

Locate the two small 22 AWG. VATS wires on the lower side of the steering column. The pass key wires connect to ignition lock cylinder.

Connect terminal 87 of the relay to the resistor, and connect the other side of the resistor to either of the Pass Key Decoder wires.

Cut the other Pass Key decoder wire.

Verify that the vehicle will not start with the ignition key.

Connect the ignition switch side of the cut wire to terminal 87A

Connect the remaining cut wire (decoder side) to terminal 30.

Connect the gray wire from the Commando Remote Start Module to terminal 85.

Connect terminal 86 to constant +12 vdc.

GM Resistor Values

- | | | |
|---------------|----------------|-----------------|
| 1. 392 ohm | 6. 1.47 K ohm | 11. 4.75 K ohm |
| 2. 523 ohm | 7. 1.87 K ohm | 12. 6.04 K ohm |
| 3. 681 ohm | 8. 2.37 K ohm | 13. 7.50 K ohm |
| 4. 887 ohm | 9. 3.01 K ohm | 14. 9.53 K ohm |
| 5. 1.13 K ohm | 10. 3.47 K ohm | 15. 11.80 K ohm |

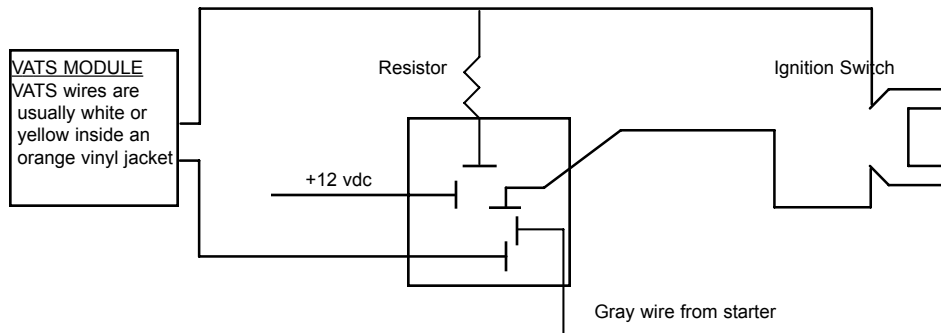

COMMANDO

REMOTE CONTROL ENGINE STARTERS

with Quick Stop, Anti-Freeze modes

with PASSLOCK and VATS installation diagrams

IMPORTANT: Unplug the wiring harnesses from the control module until ALL required wiring to the vehicle is complete.

DO NOT DISCONNECT THE BATTERY ON VEHICLES EQUIPPED WITH ANTI-THEFT RADIOS OR COMPUTERS.

SAFETY TEST: Safe operation is dependent on the proper function of the vehicle's neutral safety switch, which prevents the vehicle from starting when the transmission shift lever is in any position other than park or neutral ("in gear"). To test the neutral safety switch try to start the vehicle "in gear". If the vehicle does not start, the switch is functioning properly. Repeat the previous step for all gears other than park and neutral. If the vehicle starts when performing the above test, **DO NOT** install the remote starter unit. Contact your dealer to repair the neutral safety switch.

MOUNTING THE STARTER CONTROL MODULE

DO NOT INSTALL THE STARTER CONTROL MODULE IN THE ENGINE COMPARTMENT!

Choose a location under the dash that allows easy access to the ignition switch. Once the mounting location has been selected, secure the starter control module.

TESTING WIRES: When checking wires for voltage it is imperative that you use a **diode protected** test light. When you buy the item it will say computer safe. The best test equipment to have is a diode protected digital multi-meter you can buy these items for under \$50.00 and the meter will be a great add-on for your tool collection.

RECEIVER/ANTENNA POSITIONING: (EZ-2200 only) Route the cable along the front windshield molding and position the antenna high at the top of the windshield. **DO NOT** obstruct the antenna by metal. Avoid kinking the cable. Connect the male connector to the female connector on the starter control module. **DO NOT GROUND ANTENNA!**

STATUS LED INSTALLATION: Choose a location on the dashboard, which is visible from the outside of the vehicle. Using a 3/8" drill bit, drill a hole for mounting.

PROGRAM/OVERRIDE SWITCH INSTALLATION: Choose a location underneath the dashboard, which is inconspicuous, well hidden and not visible from the outside of the vehicle. Using a 1/4" drill bit, drill a hole for mounting.

HOOD PIN SWITCH: It is important to install the pin switch in the engine compartment for safety purposes. This will eliminate an accidental start by remote while the car is being serviced with the hood open.

EZ-2200 Stand Alone Module

TO LOCK DOORS - Press *button #1*, doors will lock, parking lights will flash one time and Status LED will flash at a slow rate. (If vehicle is equipped with power door locks.)

TO UNLOCK DOORS - Press *button #2*, doors will unlock, parking lights will flash two times and Status LED will be off. (If vehicle is equipped with power door locks.)

AUXILIARY OUTPUT - Press *button #3* for approximately three seconds. This will provide a 250ma continuous ground output if button is held, or a one-second ground pulse if released. Applications include remote power trunk/hatch release, power window roll up/down, etc. (Will require additional parts and labor.)

START MODE - Press *button #4* momentarily, parking lights will turn on, flash once in starter cranking stage and stay on while the vehicle is running in remote start mode. Status LED will flash at a fast rate. The run time for the starter is approx. 12/24 minutes. (as programmed) If the parking lights flash one time and vehicle does not crank, the remote starter has detected a faulty zone.

FAULTY ZONE SENSING - The engine will not start and the parking lights will flash one time. (1) Check if the hood is open, (2) or if the brake pedal is depressed.

TO CANCEL START MODE - (1) Press *button #4* momentarily, (2) press on brake pedal in vehicle or (3) open the vehicle's engine compartment hood. One of the previous will cancel start mode and the vehicle will shut down, Status LED will stop flashing and the doors will lock. (If equipped)

To continue normal vehicle operation while still operating in car start mode.

Perform the following steps:

Enter vehicle and turn the ignition key in the "run" position.

**** Note: Do not turn the ignition key to the crank position. The starter will grind. ****

Step on brake pedal of the vehicle. The engine will shut down and the Status LED will stop flashing, the parking lights will turn off. The vehicle will now be running normally allowing it to be driven or turned off as usual.

GARAGE MODE - Deactivates start mode. Prevents accidental starting of the vehicle.

Perform the following steps:

Turn the ignition key to on position

Press and hold the program switch until the Status LED is on solid.

Turn the ignition key off.

To cancel garage mode, repeat the above procedure. Status LED will switch off or flash if vehicle is locked.

QUICK STOP - If you would like the vehicle to continue running when you remove the ignition key. Perform the following steps:

While the vehicle is running depress the brake pedal.

Press *button #4* on the Transmitter while continuing to depress the brake pedal.

The Status LED will flash and the parking lights will switch on. At this time the ignition key can be switched off and removed and the engine will continue running.

To exit this feature, put key back into the ignition, turn to the on position and depress the brake pedal. The Status LED will stop blinking and parking light will turn off.

ANTI-FREEZE MODE - If you would like the vehicle to start every 1 1/2 hours for 12 cycles.

Perform the following steps:

Hold the program switch and *button # 2* for five seconds, the Status LED and parking lights will flash five times.

Then the engine will start and run for 30 seconds to acknowledge the activation. Once the feature is activated it will start the vehicle approximately every 1 1/2 hours for 12 cycles.

To cancel Anti- freeze mode during a cycle: (1) press *button #4* on the transmitter (2) depress the brake pedal or (3) open engine compartment hood.

LOCK WIRING DIAGRAMS:

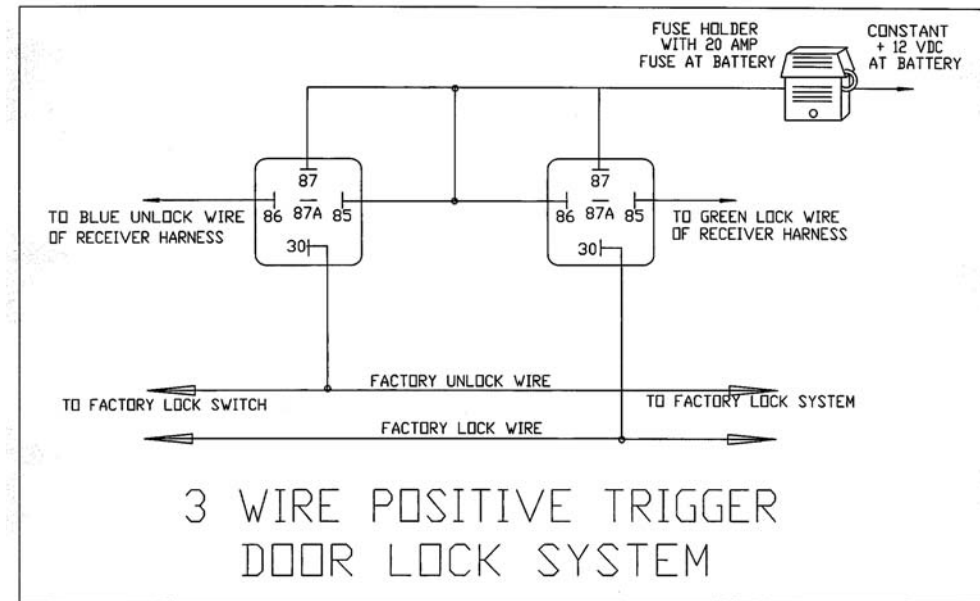
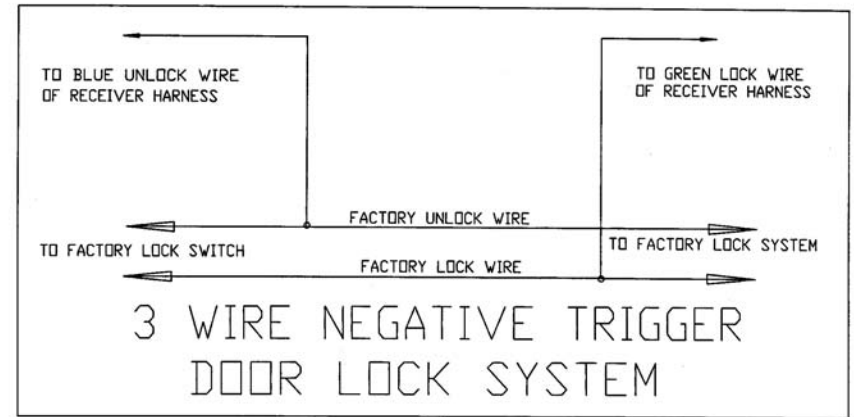

LOCK WIRING DIAGRAMS:

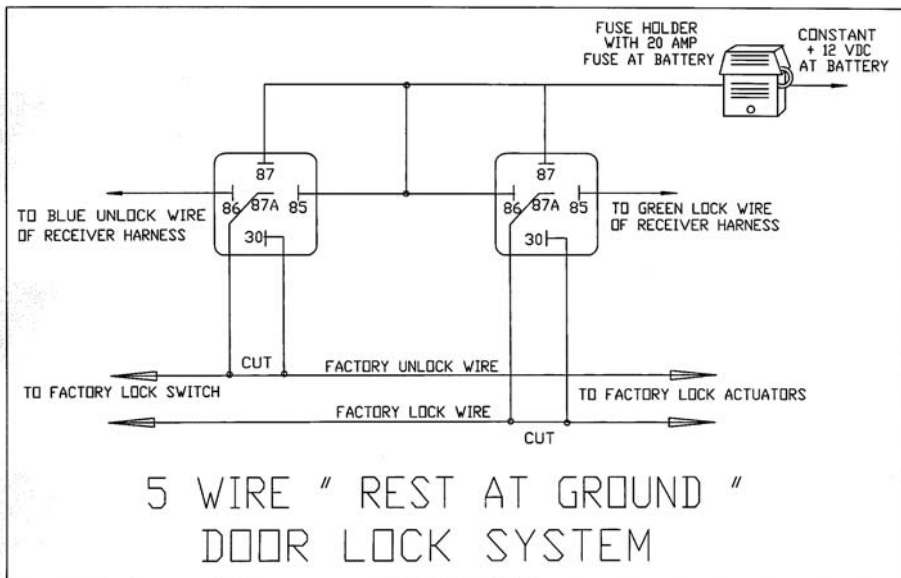
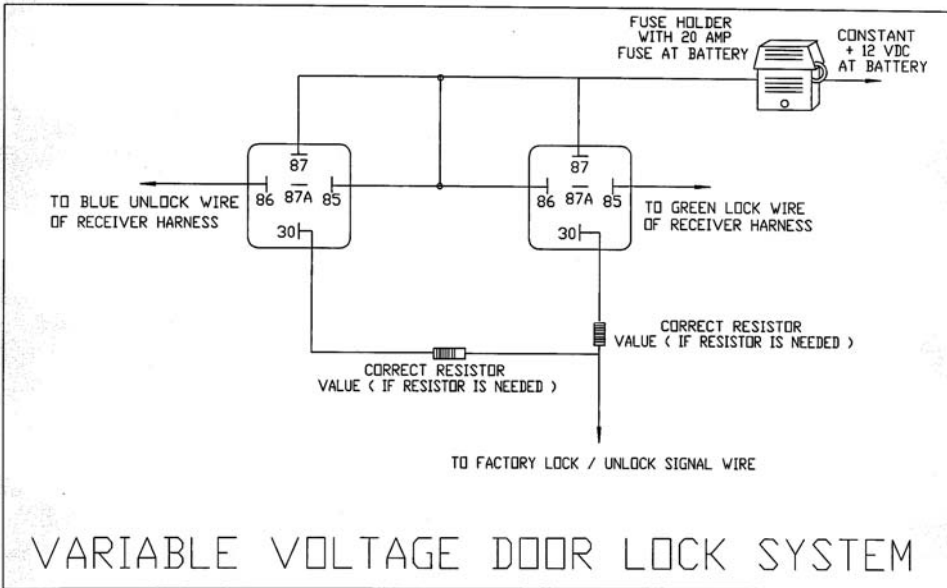

TO PROGRAM ADDITIONAL TRANSMITTERS:

Press and hold the program switch down for five (5) seconds (the parking lights will flash three times)

Press button #1 once on each of the transmitters you plan to use with the system (up to three different codes can be learned into the system).

TO ENTER PROGRAMMING MODE:

Turn the ignition switch on. Within 10 seconds, press the program button five (5) times momentarily.

The parking lights will flash 1 time to confirm you are in programming mode.

TO PROGRAM:

Press the programming switch the number of times equal to the function location.

Press **button #1** on the transmitter to select the **first option** in each location. (parking lights will flash once)

Press **button #2** on the transmitter to select the **second option** in each location. (parking lights will flash twice)

The Status LED will flash to confirm what location was programmed.

Turn the ignition key off. Status LED should be off.

Location Button#1 (first option)

- 1 Parking lights on constantly
- 2 12 minutes run time
- 3 .75 sec. lock/unlock pulse
- 4 Single door unlock pulse
- 5 Single pulse input on orange wire
- 6 Doors will lock upon starting

Button#2 (second option)

- 1 Parking lights flash every five seconds
- 2 24 minutes run time
- 3 Three (3) second lock/unlock pulse
- 4 Double door unlock pulse
- 5 Triple pulse input on orange trigger wire
- 6 Doors will not lock upon starting

To reset to the default (first option) in each location:

Enter program mode and then press **buttons #1 & #2** for 5 seconds
The parking lights will flash 3 times to confirm

Note: Each time you want to make a change to a program location you must enter programming mode

EZ-1200 Add-on Module

START MODE - Press the correct transmitter button on your keyless/alarm system. This will activate the remote starter's diagnostic mode and the parking lights will turn on and stay on while the remote starter is controlling the vehicle. The car will then start if none of the disable triggers are active. The runtime for the starter is approx. 12/24 minutes (as programmed).

TO CANCEL START MODE - (1) Press the correct transmitter button on your keyless/alarm system, (2) Step on the brake pedal of the vehicle or (3) Open and lift the engine compartment hood. One of the previous will cancel start mode and the vehicle will shut down, status LED will stop flashing and the doors will lock. (If equipped)

To continue normal vehicle operation while still operating in car start mode:

Perform the following steps:

1. Enter vehicle and turn the ignition key in the "run" position.

Note: Do not turn the ignition key to the crank position. The starter will grind.

2. Step on brake pedal of the vehicle. The remote starter will shut down and the status LED will stop flashing, the parking lights will turn off. The vehicle will now be running normally allowing it to be driven or turned off as usual.

Ten Pin Connector Color Codes

- White:** Connect to the (+) side of the parking lights.
- Red:** Connect to (+12VDC) constant supply for control module
- Brown:** Connect to the (-) trigger wire of the sensor (shock, glass, radar, etc...).
- Black:** Connect to a good chassis ground.
- Orange:** Connect to the second channel (-) output of the keyless/alarm system (1100 only).
- Gray:** Ground output when running (additional features, VATS system, Anti-grind Relay, etc...).
- Green:** Wrap around on of the vehicle spark plug wires (Spark Plug Sense Wire).
- Blue:** Connect to the hood pin switch (included) under the hood.
- Violet:** Connect to the (-) trigger sensor input wire on the alarm.
- Yellow:** Connect to the (+) brake light switch (make connection to the wire that only has power when the brake pedal is pressed).

Six Single Pin Connector Color Codes

- Purple:** Connect to the starter wire at the ignition switch, which has power present **ONLY** when in the STARTING POSITION.
- Orange:** Connect to the accessory circuit wire at the ignition switch, which has power present **ONLY** in the RUN POSITION.
- Yellow:** Connect to the ignition circuit wire at the ignition switch, which has power present **ONLY** in the RUN and STARTING POSITION. This wire supplies power to the vehicle ignition system.
- Brown:** Connect to the secondary ignition/accessory circuit wire at the ignition switch if required*
- Red:** Connect to the ignition switch (or battery) constant power 12VDC (Fuse protected 30 Amp)
- Red:** Connect to the ignition switch (or battery) constant power 12VDC (Fuse protected 30 Amp)

Secondary Connectors

- Receiver/Antenna:** Connect the antenna's plug to the module and position the other end to the windshield using the double-sided tape. (EZ-2200 only)
- Door Lock Plug:** To be used with EZ-2200 only. Connect to (-) door lock systems. Other systems use optional relays and relay sockets)
- Trunk-Green/Black:** **OPTIONAL.** Connect this wire to (-) trunk trigger wire of the factory release relay or after market release relay.
- Vacuum-Yellow:** **OPTIONAL.** Connect to one of the normally closed (-) triggers from the optional vacuum kit (D-VCM-SWT).
- Disarm-Red:** **OPTIONAL.** Connect to the factory disarm wire (-) of the automobile
- Status LED:** Connect to the red two-pin female housing on the control module
- Program Switch:** Connect to the Blue two-pin female housing on the control module

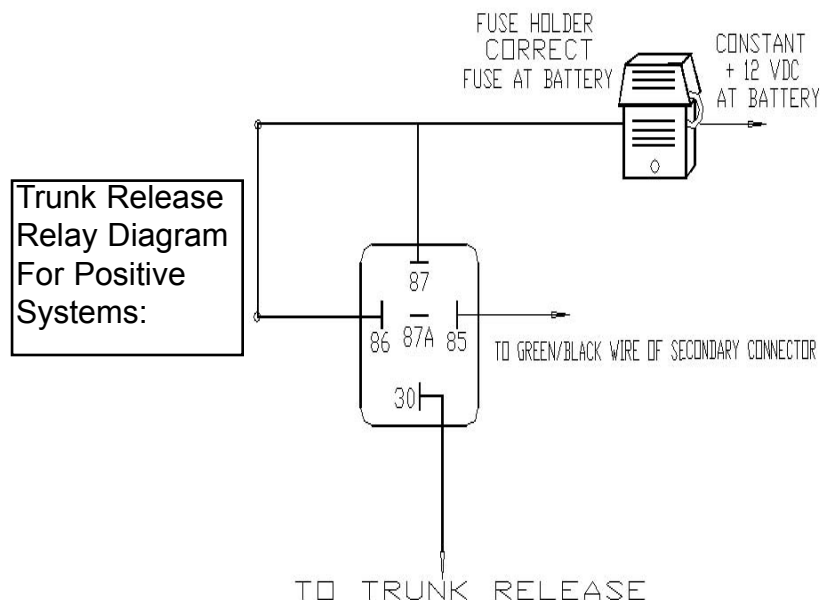

COMMANDO REMOTE ENGINE STARTERS QUICK STOP, ANTI-FREEZE WIRING DIAGRAM

EZ-1200
To be used with a Keyless/Alarm System

EZ-2200
Plug-in receiver with two transmitters w/ keyless entry
Code learning

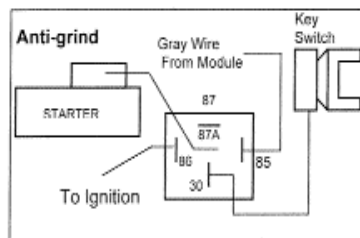

DIP SWITCH SETTINGS

Factory default Settings = "ON"

1. OFF = Spark / Tach Sense
2. OFF = Vacuum SW Input
3. OFF = Longer Crank Time
4. OFF = Diesel Mode

** All changes must be made prior to 12+

